

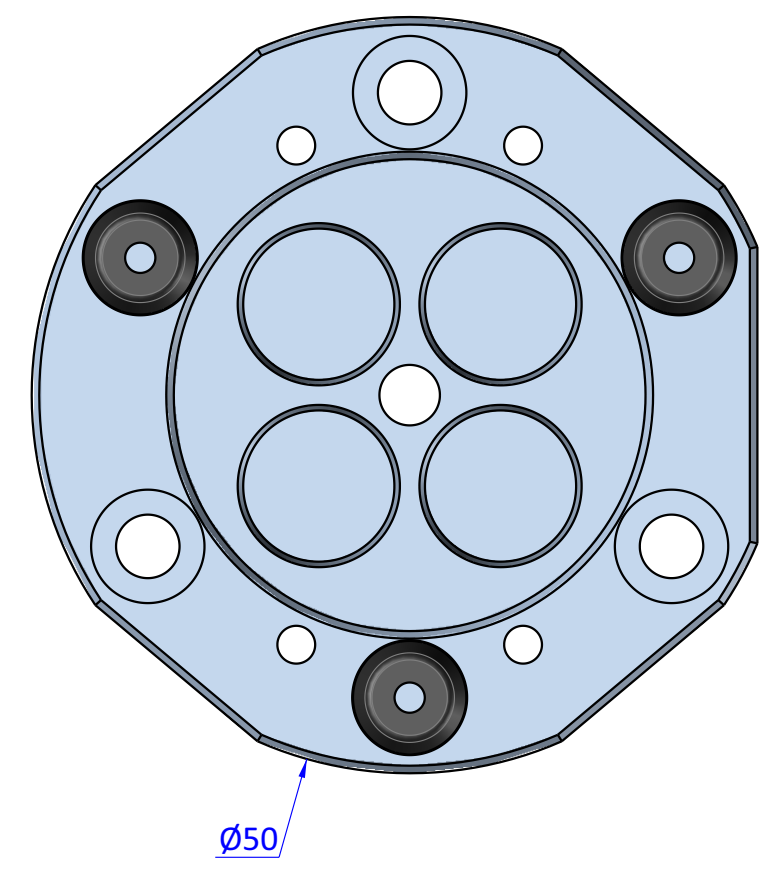

THE PROPERTY OF THE DRAWING IS ESTABLISHED BY LAW. IT IS FORBIDDEN TO PRODUCE OR SHOW IT TO THIRD PART - WITHOUT A WRITTEN AGREEMENT.

Item	Name	Q.ty
1	CUSL.50.G.01	1
2	CUSL.50.G.02	3
3	R.3.SCH	3
4	V.TCE3x8	3

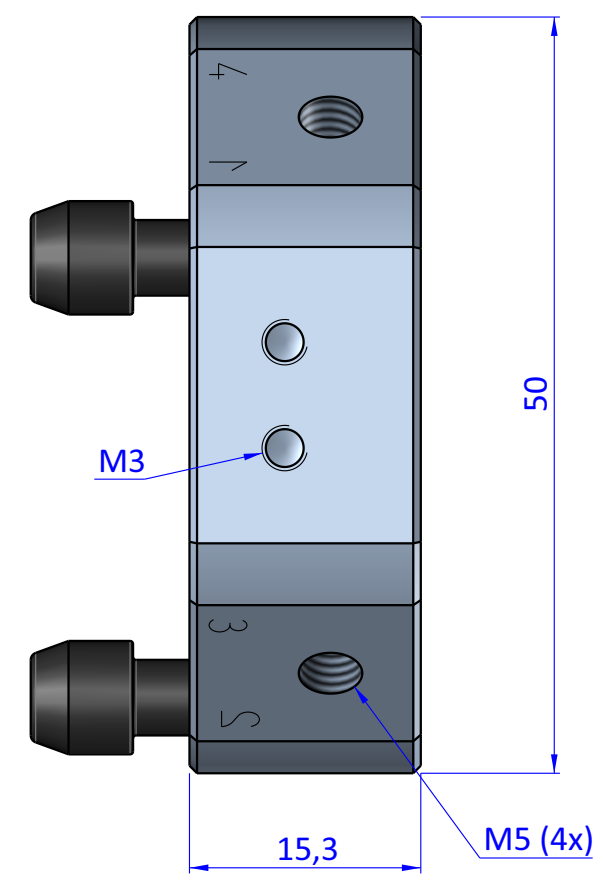
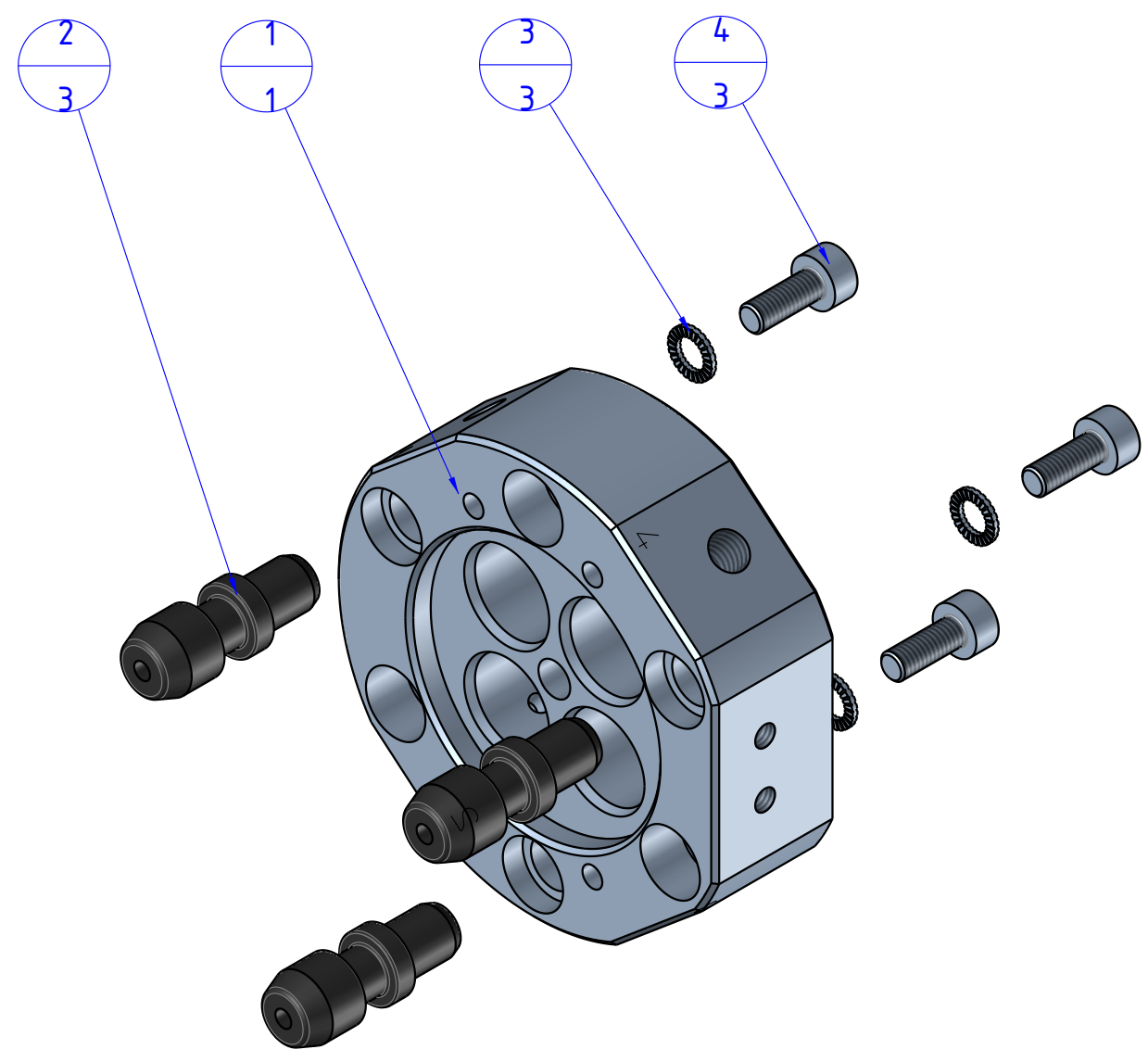

Format A3
UNI 936-76

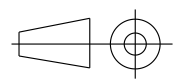
 FPS FPSERVICES AUTOMATION			DESIGNED FROM FPS Automation	REVIEW A
GENERAL TOLERANCE UNI - ISO 2768 CLASSE f	DESCRIPTION CA.CUSL.50.G	DATE 06/04/2022	WEIGHT 0,063kg	CODE CA.CUSL.50.G

THE PROPERTY OF THE DRAWING IS ESTABLISHED BY LAW. IT IS FORBIDDEN TO PRODUCE OR SHOW IT TO THIRD PART WITHOUT A WRITTEN AGREEMENT.

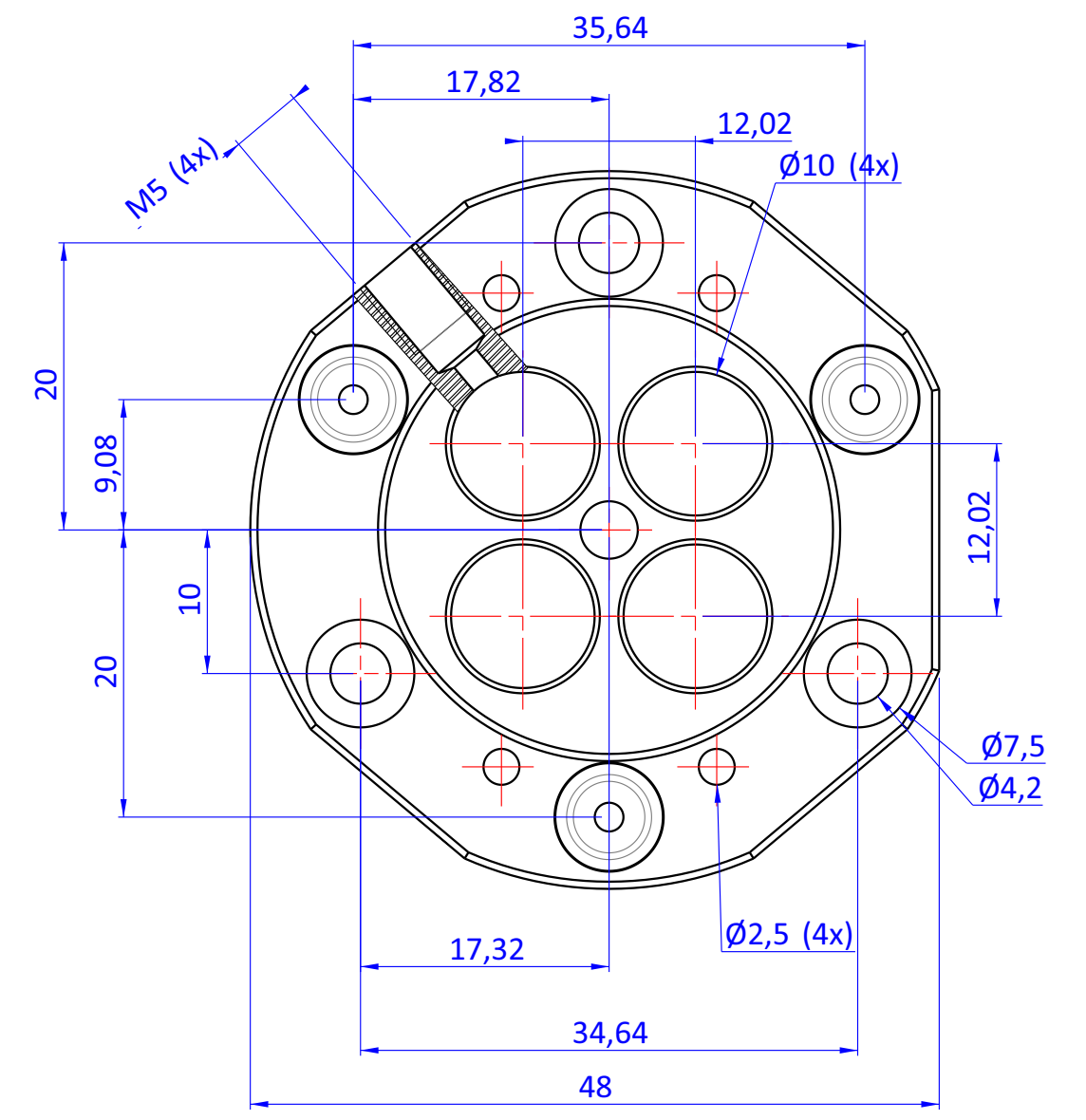
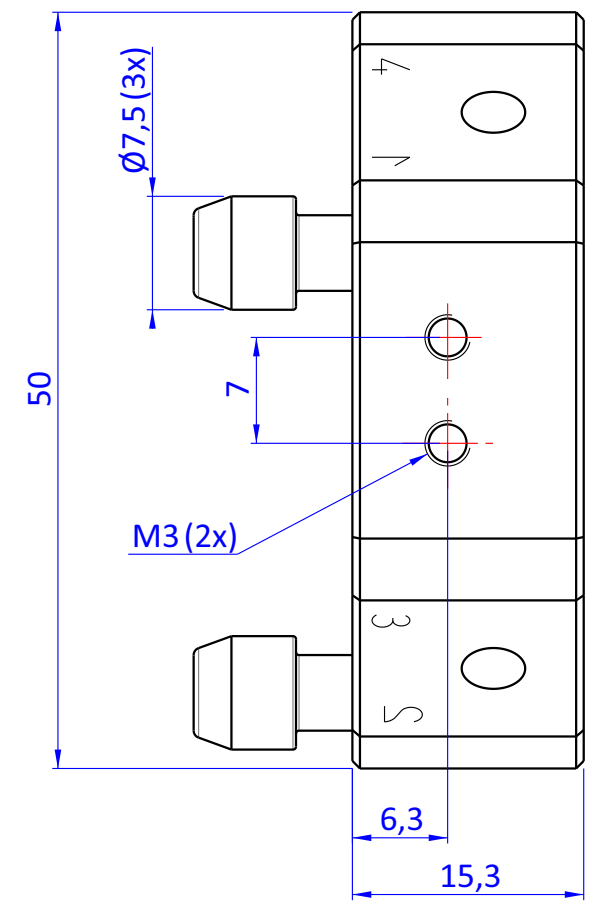
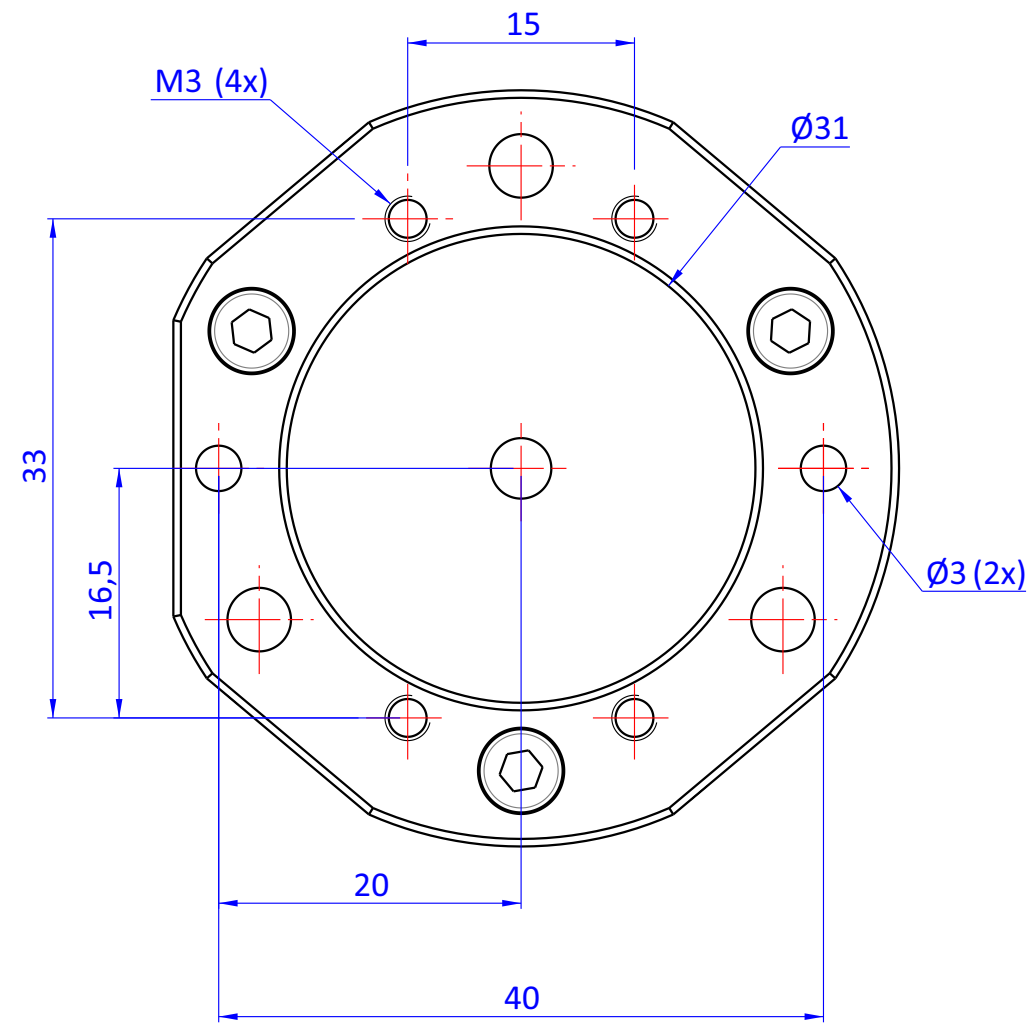

Format A3
UNI 936-76

 FPS FPSERVICES AUTOMATION		DESIGNED FROM FPS Automation		REVIEW A	
		DATE 06/04/2022	WEIGHT 0,063kg		
GENERAL TOLERANCE UNI - ISO 2768 CLASSE f	DESCRIPTION CA.CUSL.50.G		CODE CA.CUSL.50.G		